

SILO CONE 65°

ELEVATION VIEW
5'-4 7/16"

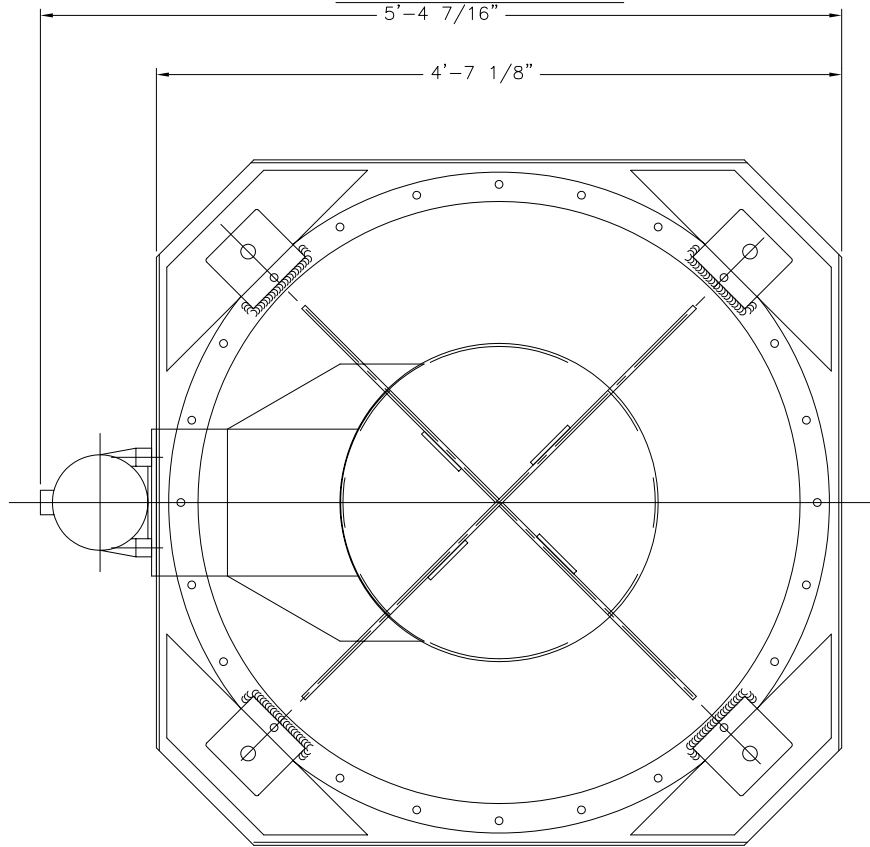

TAG EQP'T 40.022.000

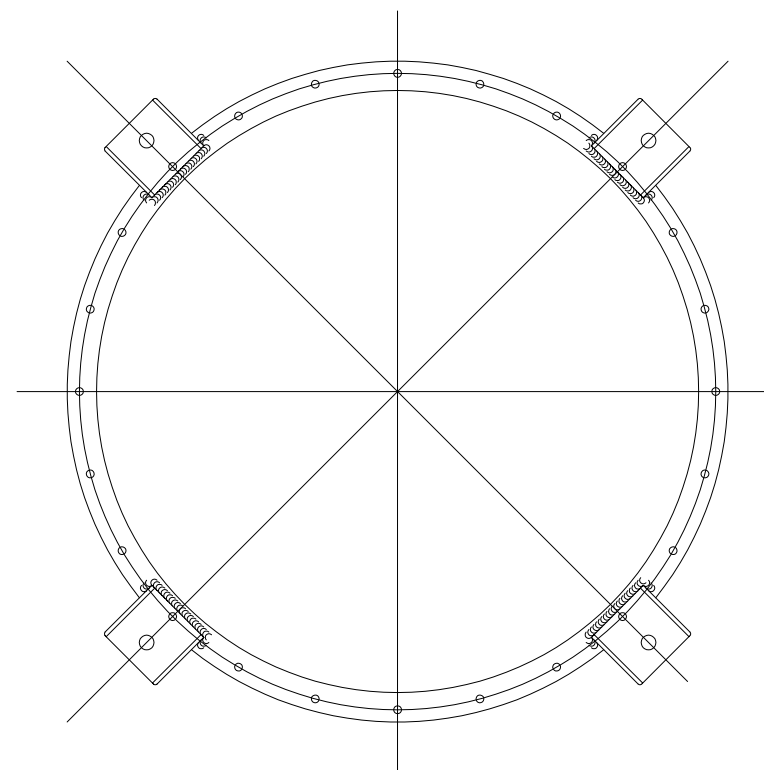

NOTES:

1. MATERIAL OF CONSTRUCTION:
HOUSING, STAINLESS STEEL , ZINC PALTED COMPANION FLANGES TO CONNECT SLEEVE
2. BOLT IN DEFLECTOR.
3. PROVIDE FLEXIBLE DISCHARGE BOOT AND CLAMPS.
4. PAINT SPECIFICATIONS:
CARBON STEEL ACTIVATOR PARTS SHALL BE SURFACE PREPARED AND PAINTED WITH EPOXY PRIMER AND POLYURETHANE TOPCOAT. THIS INCLUDES ALL MOTORS, DRIVES, GUARDS, AND OTHER CARBON STEEL APPURTENANCES.
5. MANUFACTURER SHALL TAG ALL COMPONENTS BEFORE SHIPPING. ONE EXTRA COPY OF THE INSTALLATION INSTRUCTIONS SHALL BE INCLUDED IN SHIPMENT.
6. ACTIVATOR ON RECYCLE BIN IS SIMILAR.

EQUIPMENT SPECIFICATIONS

MANUFACTURER	WAM
BLOWER MODEL	BA.2.1.125.04.ST323
INLET FLANGE	48" NOMINAL
MOTOR	.35Kw (1/2 HP) 460/3/60 TEFC
CAPACITY	50 TPH

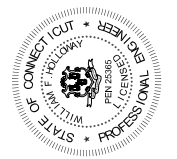

DATE:	12/22/05	DATE:	01/17/07
DRAWN BY:	JEN	CHECKED BY:	
APPROVED BY:		SCALE:	1" = 1/2" = 1'-0"
FILE:	152402200	REV:	0
TITLE:	DDS40	REVISION:	1
PROJECT NUMBER:	1524	DATE:	06/05/06
DRAWING NUMBER:	022-00	DATE:	
SHEET:	1 OF 1	REVISION:	0
		DATE:	01/17/07
		DATE:	06/05/06

JOB NAME: CITY OF STAMFORD CONNECTICUT SOLIDS DRYING PROJECT
 TITLE: SILO BIN ACTIVATOR (022) GENERAL ARRANGEMENT
 PROJECT NUMBER: 1524
 DRAWING NUMBER: 022-00
 SHEET: 1 OF 1

THIS DRAWING IS COPY RIGHTED. THIS DRAWING IS A TRADE SECRET AND ONLY ENTRUSTED TO THE RECEIVER FOR HIS PERSONAL USE. WITHOUT THE SIGNED WRITTEN CONSENT OF ANDRITZ-RUTHNER, INC., IT MUST NOT BE COPIED NOR MADE AVAILABLE TO THIRD PARTIES. INCLUDING COMPETITORS, NOR MADE ACCESSIBLE TO SUCH PARTIES. ANY ILLEGAL USE BY THE RECEIVER OR THIRD PARTIES FOR WHICH HE IS RESPONSIBLE CAN CONSTITUTE A CAUSE FOR LEGAL ACTION. THIS DRAWING MUST BE RETURNED ON REQUEST OF THE COMPANY.

