

PLAN VIEW

11 GA
304-SS (TYP)

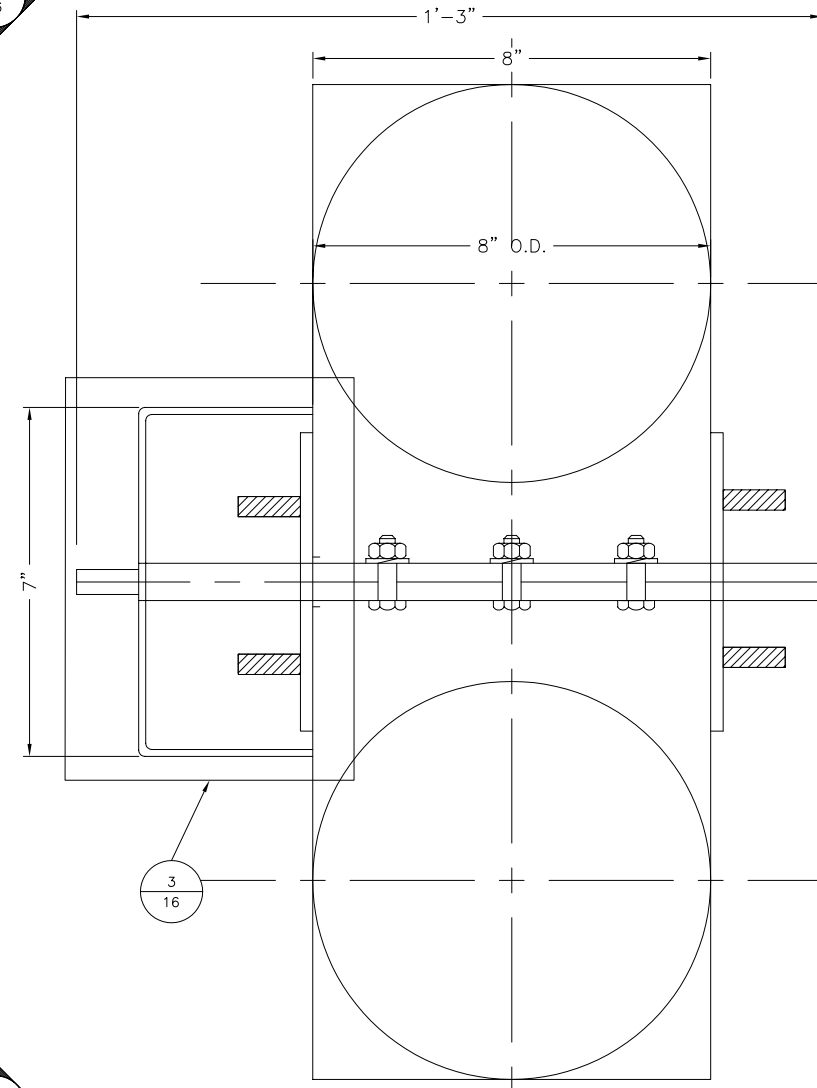

A VIEW
6"=1'-0"

NOTES:

- MATERIAL OF CONSTRUCTION:**
HOUSING 304-SS
BLADE 304-SS
- WELDING PER AWS STANDARDS. WELD MUST BE FREE OF GAS BUBBLS. CLEAN AND DRESS UP ALL WELDS.**
- AIR ACTUATOR/POSITIONER TO BE FROM RADIUS.**
- FABRICATOR TO SUPPLY ALL FASTENERS INCLUDING BOLTS, NUTS, FLAT AND LOCK WASHERS, AND ALL OTHER MISC. HARDWARE.**
- MANUFACTURER TO TAG ALL COMPONENTS (BEFORE SHIPPING) FOR ASSEMBLY.**

EQUIPMENT SPECIFICATIONS

MANUFACTURER ANDRITZ
DIVERTER MODEL DDS-60
THRUPUT 12 TPH NOMINAL
ACTUATOR RADIUS

TAG EQP'T 40.009.310

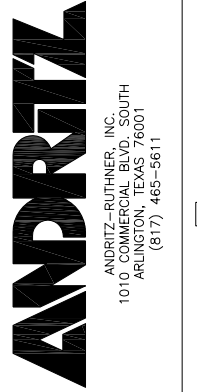

DATE: 3/25/06	DATE: 06/05/06
CHECKED BY: JEN	REV: 0
APPROVED BY:	FOR FINAL REVIEW/BUILDING PERMIT
SCALE: 1/2"=1'-0"	REVISION
FILE: 152400915	DATE
SIZE	

JOB NAME	CITY OF STAMFORD CONNECTICUT
PROJECT NUMBER	SOLIDS DRYING PROJECT
TITLE	PRODUCT SIZING SCREEN (009)
	GENERAL ARRANGEMENT
DRAWING NUMBER	1524
	009-15
SHEET	1 OF 1

THIS DRAWING IS COPY RIGHTED AND IS THE PROPERTY OF ANDRITZ-RUTHNER, INC. IT MUST NOT BE COPIED NOR MADE AVAILABLE TO THIRD PARTIES. INCLUDING COMPETITORS, NOR MADE ACCESSIBLE TO SUCH PARTIES. ANY ILLEGAL USE BY THE RECEIVER OR THIRD PARTIES FOR WHICH HE IS RESPONSIBLE CAN CONSTITUTE A CAUSE FOR LEGAL ACTION. THIS DRAWING MUST BE RETURNED ON REQUEST OF THE COMPANY.

