

NOTES:

1. MATERIAL OF CONSTRUCTION: WHEEL A242 , SHAFT 1018 STEEL, HOUSING A36 3/8" THICK, BALANCE A36 PLATE
2. CARBON STEEL PAINT SPECIFICATIONS: SP-6 SURFACE PREP WITH INORGANIC ZINC PRIMER.
3. FABRICATOR TO PROVIDE (2) T-TECTEMP & (1) VITEC VIBRATION DETECTORS.
4. FAN & MOTOR BASE TO BE MOUNTED ON CONCRETE.
5. FABRICATOR TO SUPPLY ALL FASTENERS INCLUDING BOLTS, NUTS, FLAT AND LOCK WASHERS, AND ALL OTHER MISCELLANEOUS HARDWARE.
6. BOLTED STRUCTURAL CONNECTIONS TO BE ASTM A-325 UNLESS OTHERWISE NOTED.
7. MANUFACTURER TO TAG ALL COMPONENTS (BEFORE SHIPPING) FOR ASSEMBLY. PROVIDE ONE EXTRA COPY OF INSTALLATION INSTRUCTIONS WITH SHIPMENT.

EQUIPMENT SPECIFICATIONS

MANUFACTURER	ROBINSON
MODEL	RB-1222
MOTOR	150 HP 460/3/60 TEFC
CAPACITY	25,000 ACFM @ 27 IN. W.G.
PROCESS AIR TEMP	200° F OUTLET TEMP.
SPEED	1,800 RPM
DAMPER	MATRYX MX-45
AIR REQ'T	2 CFM @ 60 PSI
MAX WEIGHT	3,600 LBS

TAG EQP'T 40.005.000

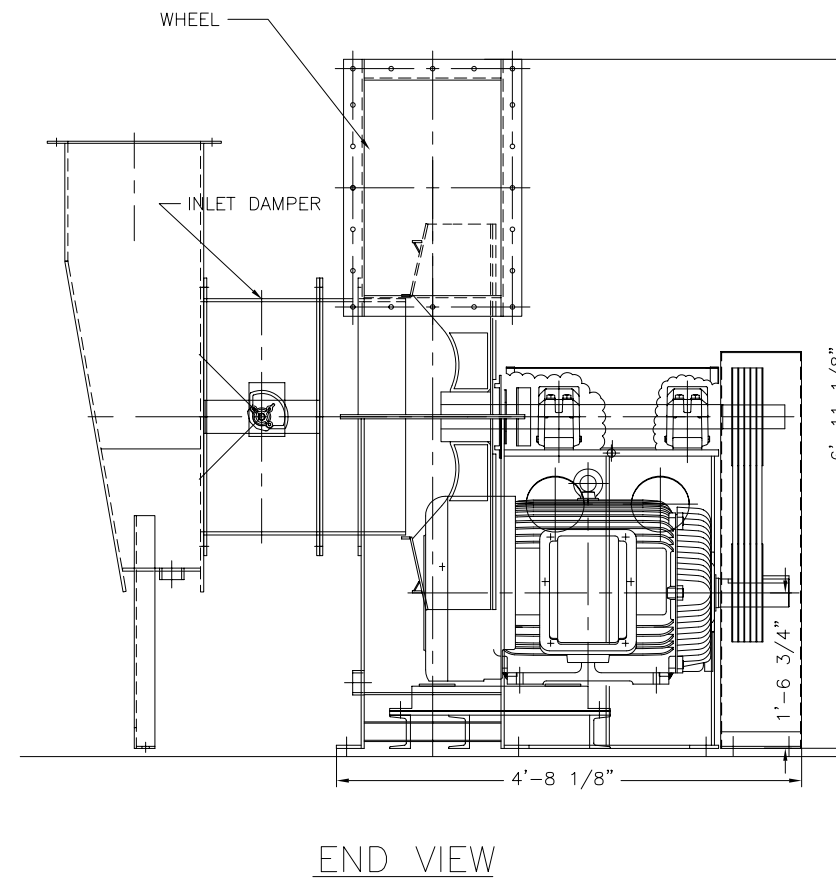
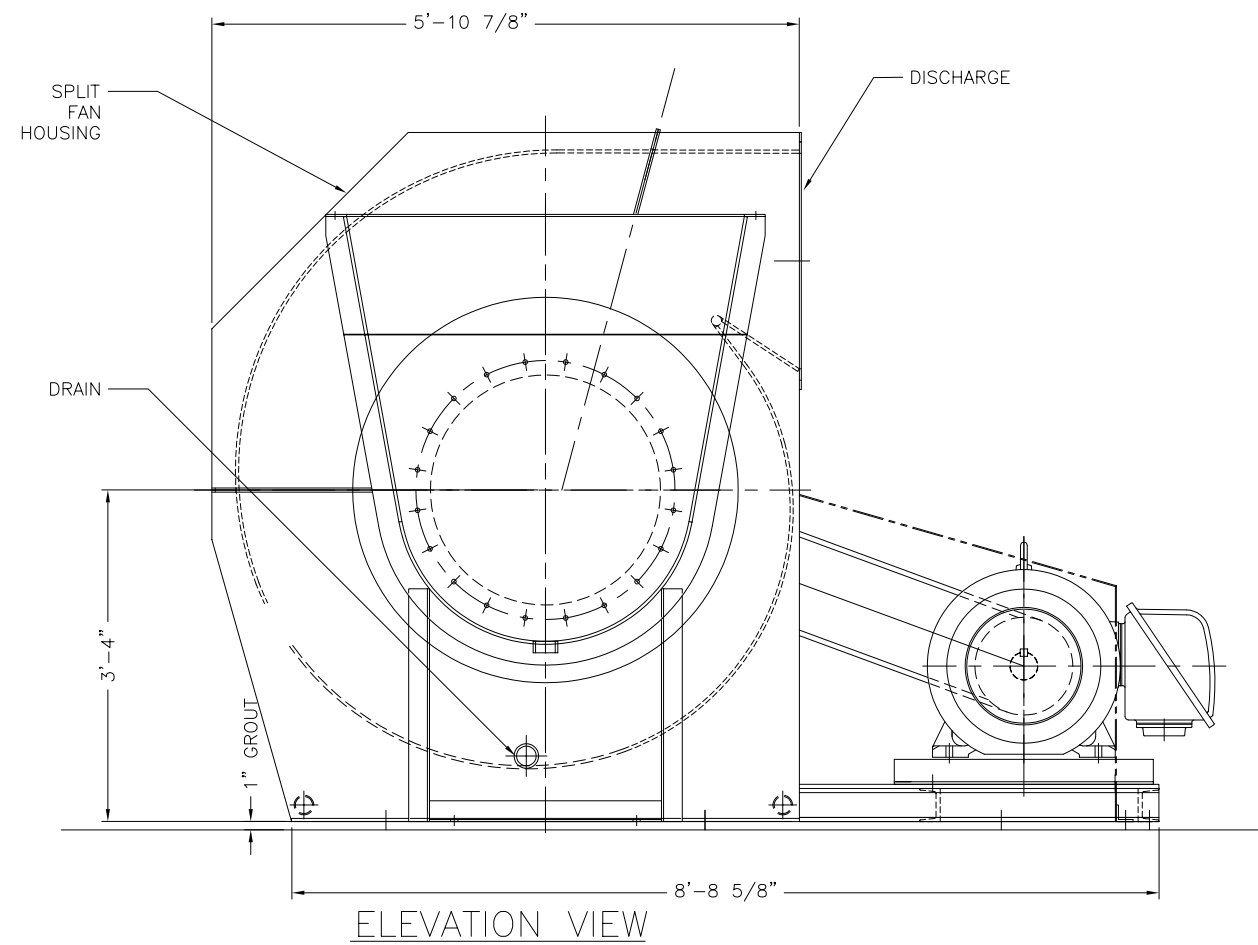

DATE:	12/20/05
DRAWN BY:	JEN
CHECKED BY:	
APPROVED BY:	
SCALE:	1" = 1'-0"
FILE:	152400500
REV	0
REV	1
REVISION	FOR FINAL REVIEW/BUILDING PERMIT
DATE	01/16/07
DATE	06/05/06

JOB NAME	CITY OF STAMFORD CONNECTICUT SOLIDS DRYING PROJECT
TITLE	INDUCED DRAFT FAN (005) GENERAL ARRANGEMENT
PROJECT NUMBER	1524
DRAWING NUMBER	005-00
SHEET	1 OF 1

THIS DRAWING IS COPYRIGHTED AND IS A TRADE SECRET AND ONLY ENTRUSTED TO THE RECEIVER FOR HIS PERSONAL USE. WITHOUT THE SIGNED WRITTEN CONSENT OF ANDRITZ-RUTHNER, INC., IT MUST NOT BE COPIED NOR MADE AVAILABLE TO THIRD PARTIES. INCLUDING COMPETITORS, NOR MADE ACCESSIBLE TO SUCH PARTIES. ANY ILLEGAL USE BY THE RECEIVER OR THIRD PARTIES FOR WHICH HE IS RESPONSIBLE CAN CONSTITUTE A CAUSE FOR LEGAL ACTION. THIS DRAWING MUST BE RETURNED ON REQUEST OF THE COMPANY.

